

HDZ3S系列 滑軌型平行機械夾

動作規格表與訂購稱呼說明



CHELIC PNEUMATIC

特點

- 一體化設計之線性導軌:高剛性、高精度
- 內置式感應磁石



規格表

項目	缸徑(mm)	Ø6	Ø10	Ø16	Ø20	Ø25	Ø32	Ø40
使用流體		空氣						
使用壓力範圍	雙作用	0.15~0.7MPa	0.2~0.7MPa	0.1~0.7MPa			0.1~0.7MPa	
	單作用	0.3~0.7MPa	0.35~0.7MPa	0.25~0.7MPa			0.25~0.7MPa	
環境及流體溫度		-10~60°C (未凍結)						
重複精度		±0.01mm					±0.02mm	
最高使用頻率(c.p.m)		180					60	
潤滑		不需要						
動作方式		復動式/單動式						
接管口徑		M3×0.5			M5×0.8			

訂購稱呼代號

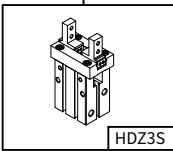
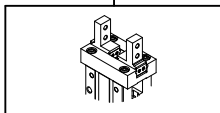
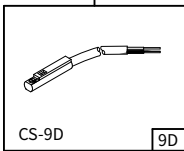
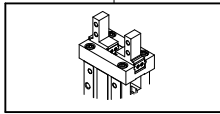
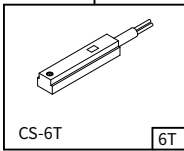
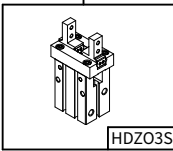
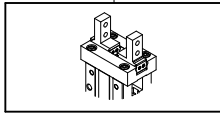
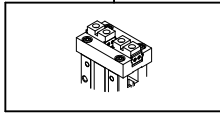
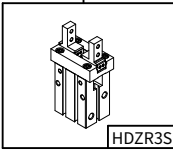
HDZ3S	—	16	—	B	—	9D	—	1
機種仕樣		氣缸內徑		爪片型式(標準型)		感應器裝置		感應器數量
		06- Ø6 mm 10- Ø10 mm 16- Ø16 mm 20- Ø20 mm 25- Ø25 mm 32- Ø32 mm 40- Ø40 mm		 無記號:基本型		 CS-9D 9D (適用於除Ø10外所有缸徑)		1: 1個感應器 2: 2個感應器
HDZ3S:標準復動式				 B:側面攻牙型		 CS-6T 6T (適用於所有缸徑)		
				 C:開關方向通孔型				
HDZ03S:單動式常開型				 D:扁平夾爪型				
								
HDZR3S:單動式常閉型								

HDZ3S系列 滑軌型平行機械夾



CHELIC PNEUMATIC

爪片夾持作用表

爪片夾持作用表

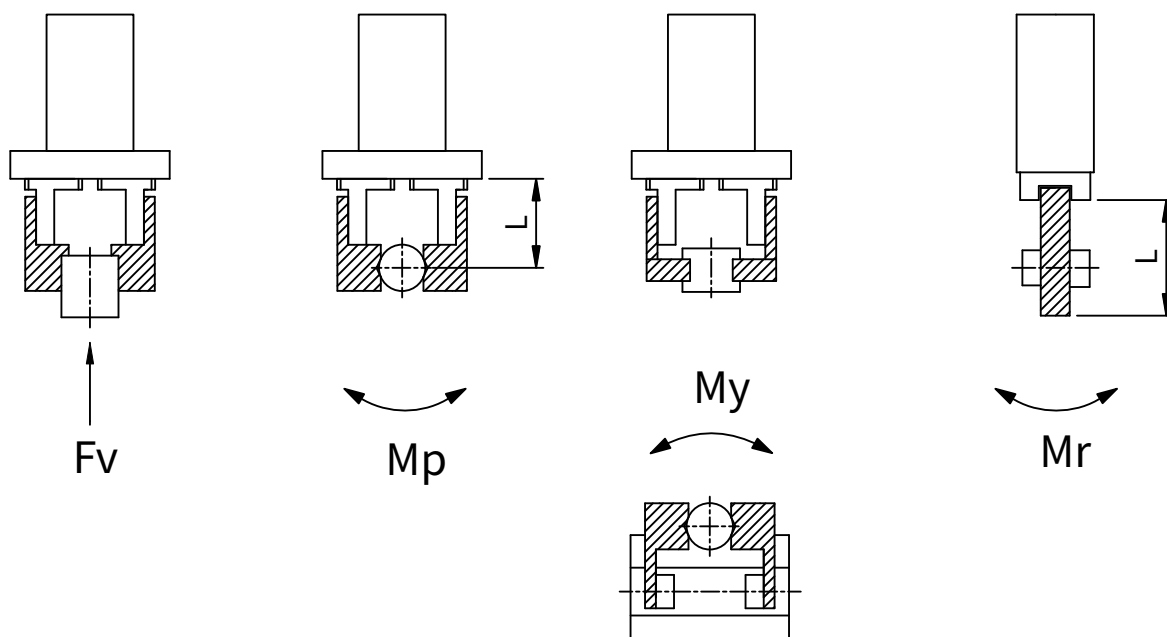

型號	垂直方向負載重 Fv(N)	最大允許力矩		
		轉向彎曲力矩Mp(N.M)	偏轉力矩My(N.M)	回轉力矩Mr(N.M)
HDZ3S 06	10	0.04	0.04	0.08
HDZ3S 10	58	0.26	0.26	
HDZ3S 16	98	0.68	0.68	1.36
HDZ3S 20	147	1.32	1.32	
HDZ3S 25	255	1.94	1.94	3.88
HDZ3S 32	343	3	3	6
HDZ3S 40	490	4.5	4.5	9

注:表中的負載和力矩值為靜態值. L: 到施加負載點的距離(mm)

允許外力的計算 (承受力矩負載時)	計算示例
$\text{允許負載 } F(\text{N}) = \frac{M(\text{靜允許力矩})(\text{N.m})}{L \times 10}$ <p style="text-align: center;">↑ 單位換算定數</p>	<p>HDZ3S 16的導軌至L=30mm的點有f=10N的靜負載產生的軸向彎曲力矩的場合可使用</p> $\text{允許負載 } F = \frac{0.68}{30 \times 10}$ $= 22.7(\text{N})$ <p>允許負載f=10(N) < 22.7(N)</p>

夾持力選型與計算

推薦計算公式
 F: 單個夾爪的夾持力
 μ: 摩擦係數
 m: 工件質量
 g: 重力加速度 (9.8m/s)²
 mg: 工件重量

$$2 \times \mu F > mg$$

↑
兩個夾爪

a: 安全係數

$$F = \frac{mg}{2 \times \mu} \times a$$
 (推薦 a=4)

夾持力對照表

理論壓強為0.5MPa的情況下:

型號	夾持力N (每個夾爪 夾持力的有效值)				開閉行程 (兩側) mm
	雙動		單動		
	外徑	內徑	外徑	內徑	
HDZ3S-06	3.3	6.1	1.9	3.7	4
HDZ3S-10	11	17	7.1	13	4
HDZ3S-16	34	45	27	38	6
HDZ3S-20	42	66	33	57	10
HDZ3S-25	65	104	45	83	14
HDZ3S-32	158	193	131	161	22
HDZ3S-40	254	318	217	267	30

HDZ3S系列 滑軌型平行機械夾



CHELIC PNEUMATIC

外徑夾持力特性圖

外徑夾持力特性圖

如下圖，當夾爪和附件與工件完全接觸時，夾爪夾持力與距離L應參照右圖

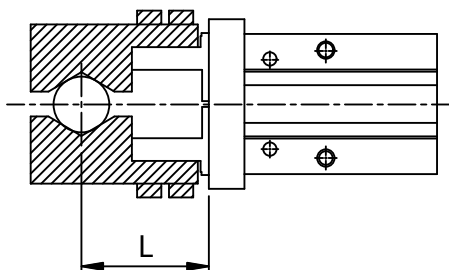

HDZ3S 06

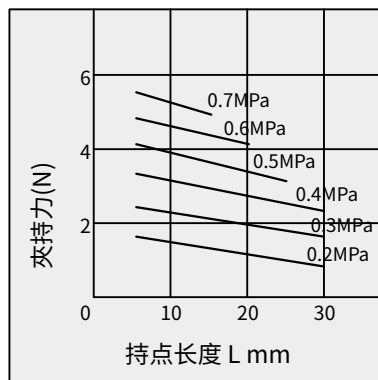

HDZ3S 10

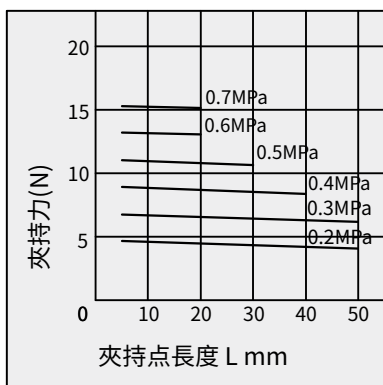

HDZ3S 16

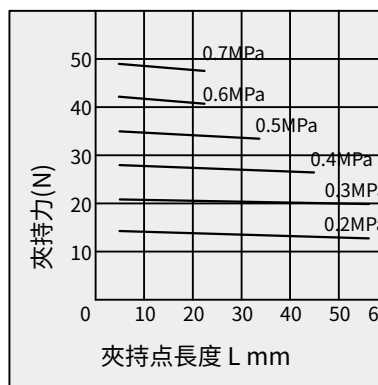

HDZ3S 20

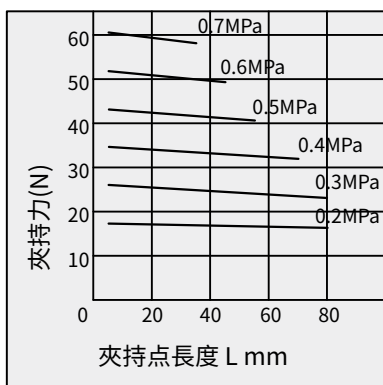

HDZ3S 25

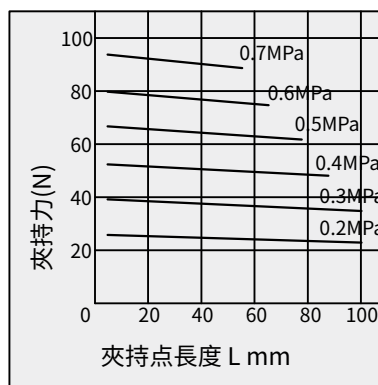

HDZ3S 32

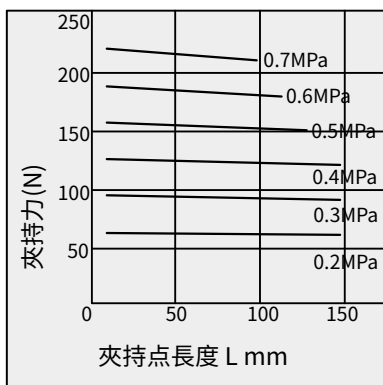

HDZ3S 40

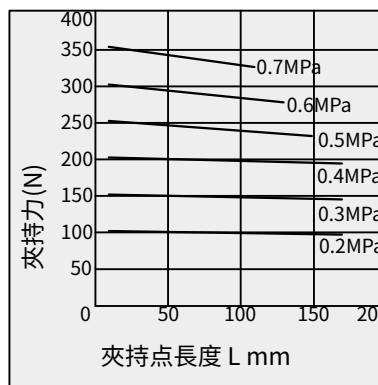

HDZ3S系列 滑軌型平行機械夾



CHELIC PNEUMATIC

內徑夾持力特性圖

內徑夾持力特性圖

如下圖，當夾爪和附件與工件完全接觸時，夾爪夾持力與距離L應參照右圖

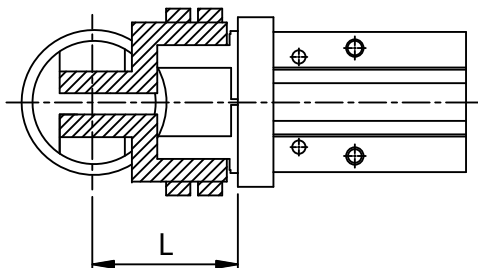

HDZ3S 06

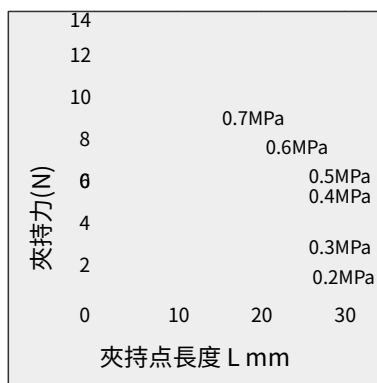

HDZ3S 10

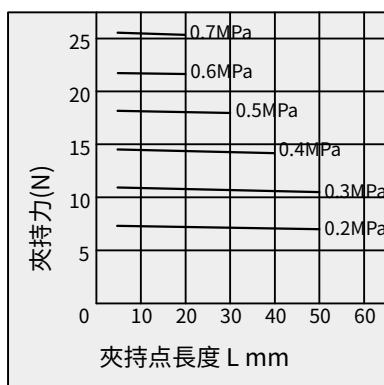

HDZ3S 16

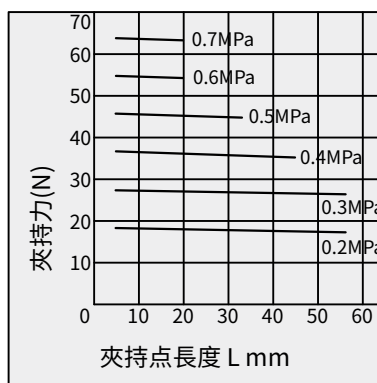

HDZ3S 20

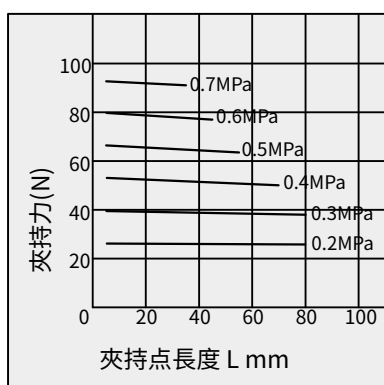

HDZ3S 25

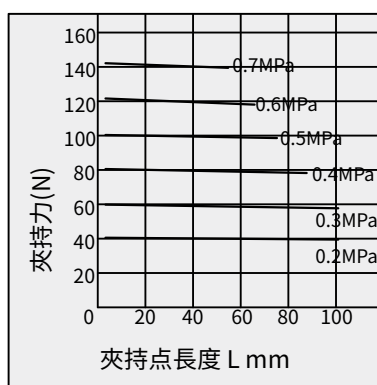

HDZ3S 32

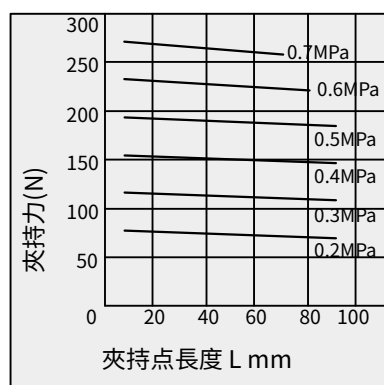

HDZ3S 40

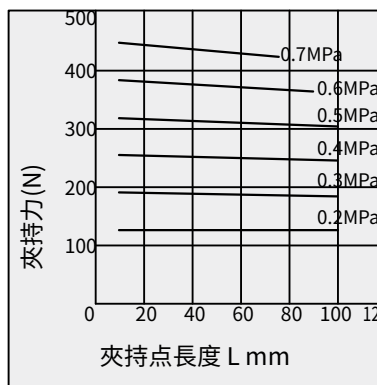

HDZ3S系列 滑軌型平行機械夾

夾爪最大允許偏移量



CHELIC PNEUMATIC

夾爪最大允許偏移量-外徑夾持

夾爪安裝使用時，相對應的H,L值應該符合右圖曲線
如果超過該範圍，將影響氣缸的壽命

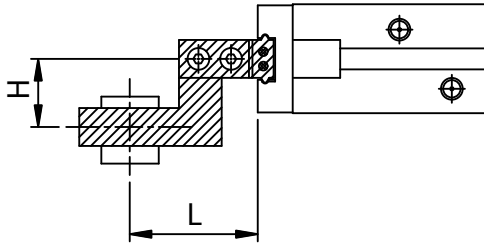

HDZ3S 06

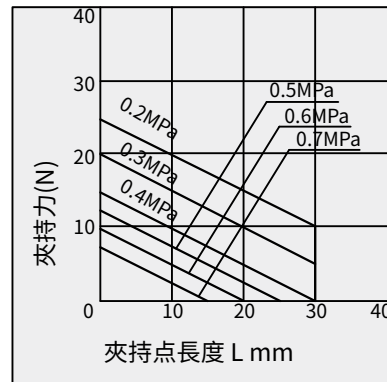

HDZ3S 10

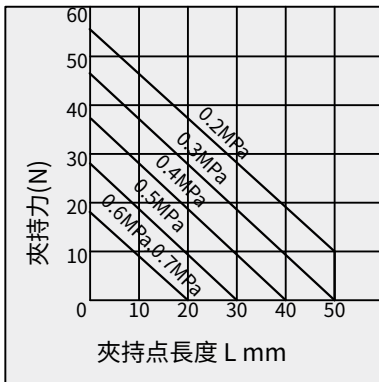

HDZ3S 16

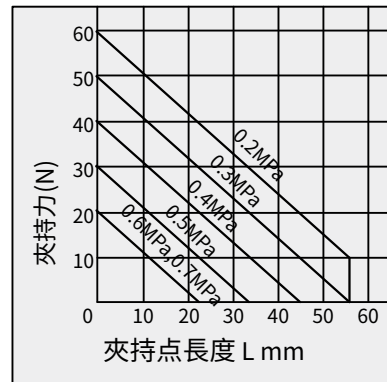

HDZ3S 20

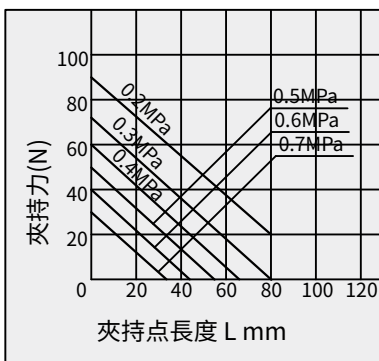

HDZ3S 25

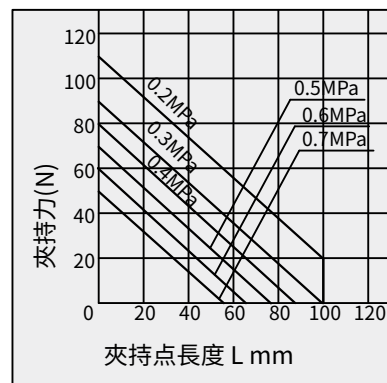

HDZ3S 32

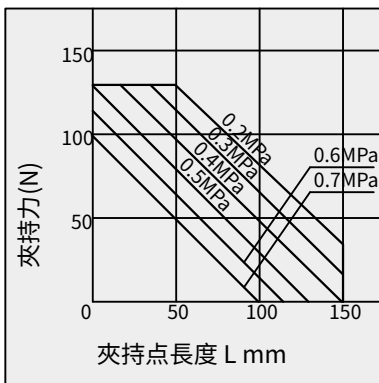

HDZ3S 40

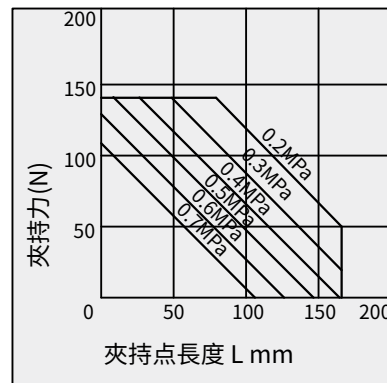

HDZ3S系列 滑軌型平行機械夾

夾爪最大允許偏移量



CHELIC PNEUMATIC

夾爪最大允許偏移量-內徑夾持

夾爪安裝使用時，相對應的H,L值應該符合右圖曲線
如果超過該範圍，將影響氣缸的壽命

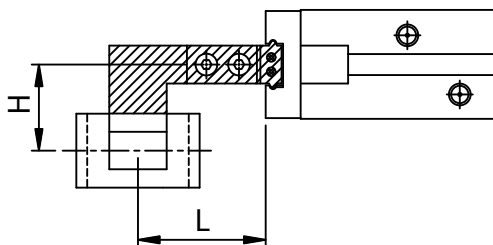

HDZ3S 06

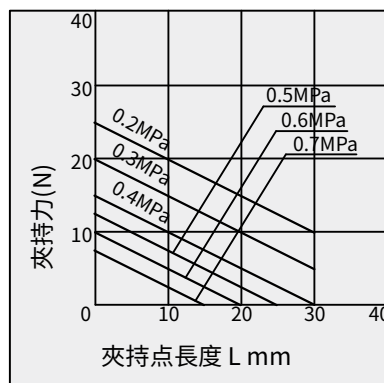

HDZ3S 10

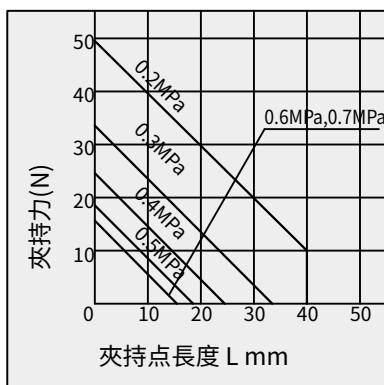

HDZ3S 16

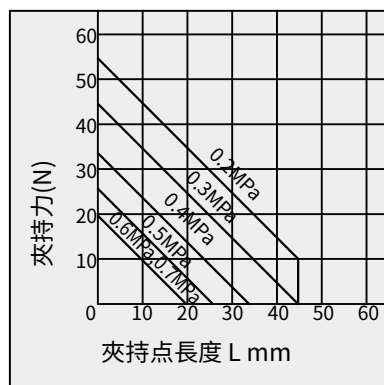

HDZ3S 20

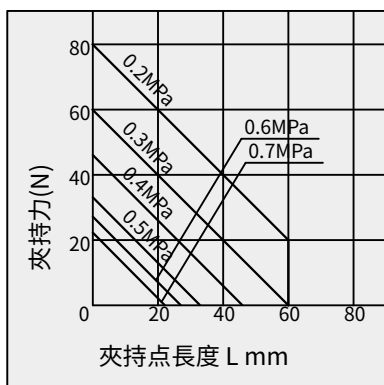

HDZ3S 25

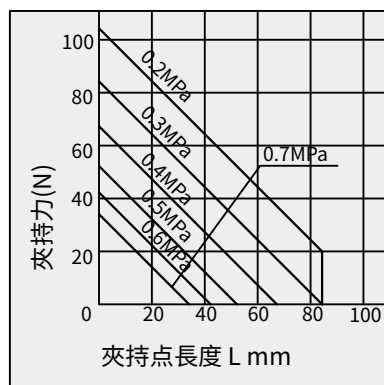

HDZ3S 32

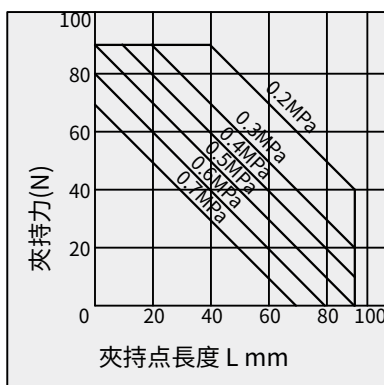

HDZ3S 40

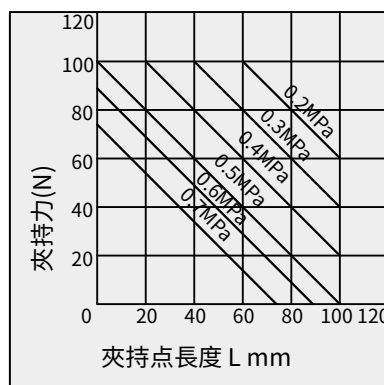

HDZ3S系列 滑軌型平行機械夾

外觀圖形尺寸



CHELIC PNEUMATIC

HDZ3S 06 (標準型)

復動型/單動型

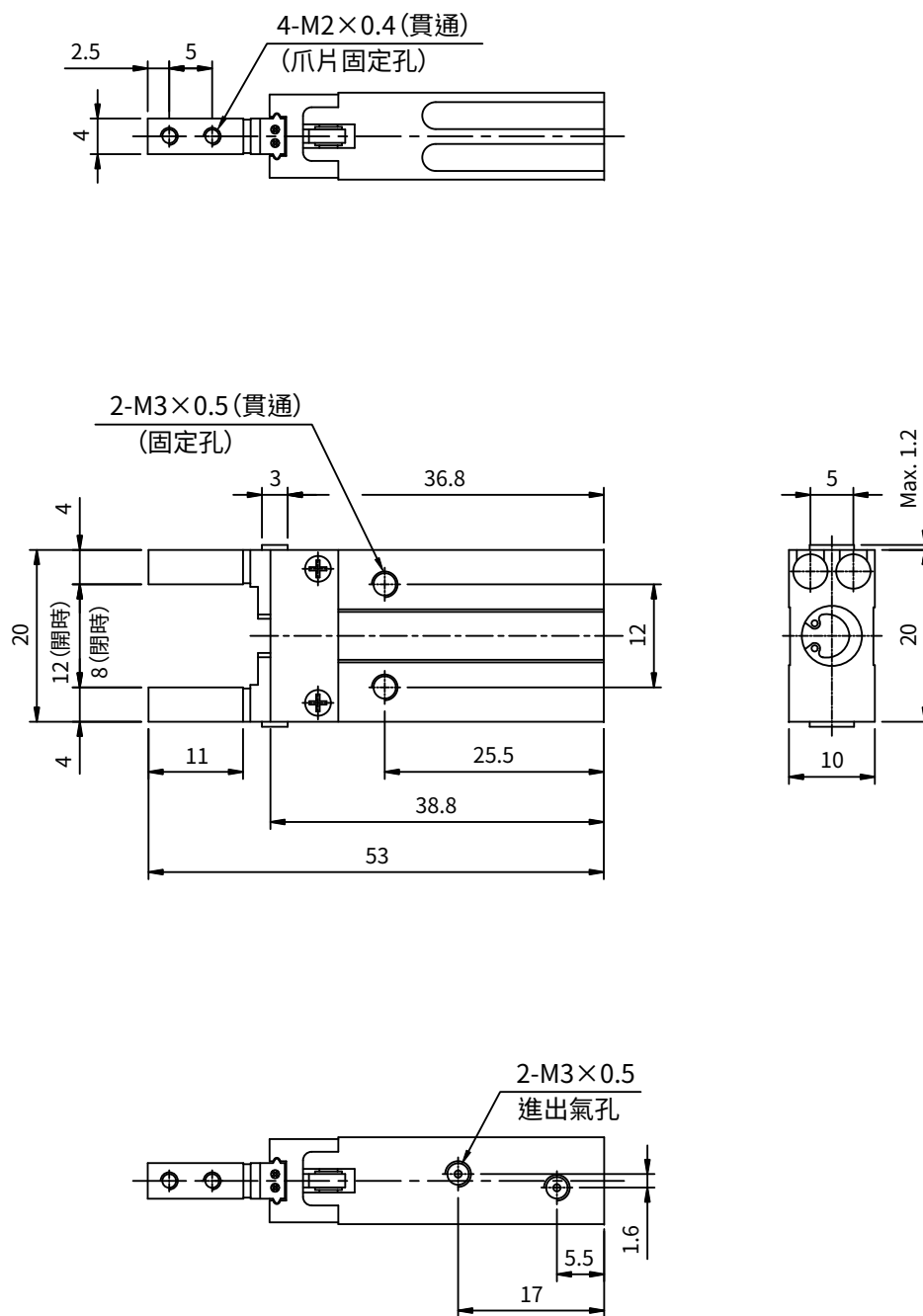

*單作用的場合，一側通孔變成呼吸孔

HDZ3S系列 滑軌型平行機械夾

外觀圖形尺寸



CHELIC PNEUMATIC

HDZ3S 10 (標準型)

復動型/單動型

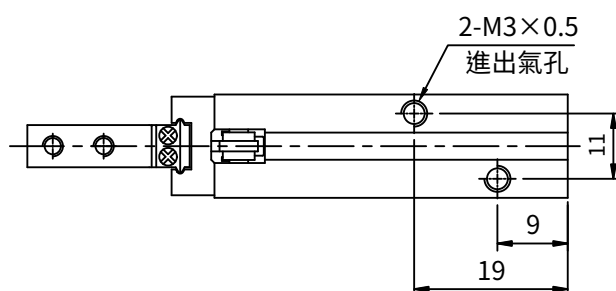
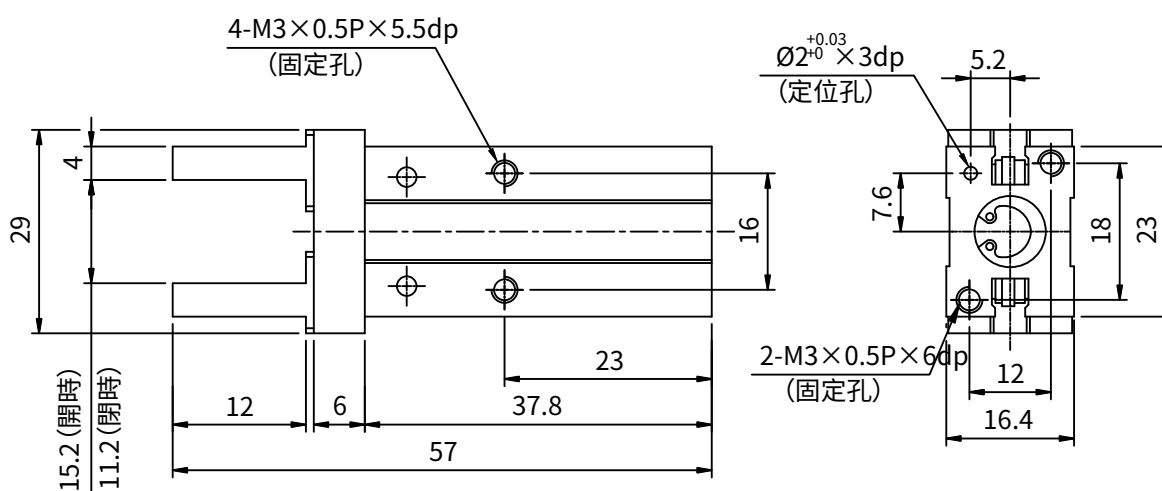
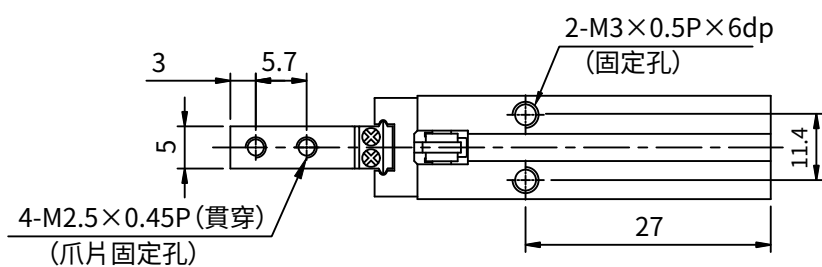

*單作用の場合、一側通孔變成呼吸孔

HDZ3S系列 滑軌型平行機械夾

外觀圖形尺寸



CHELIC PNEUMATIC

HDZ3S 16 (標準型)

復動型/單動型

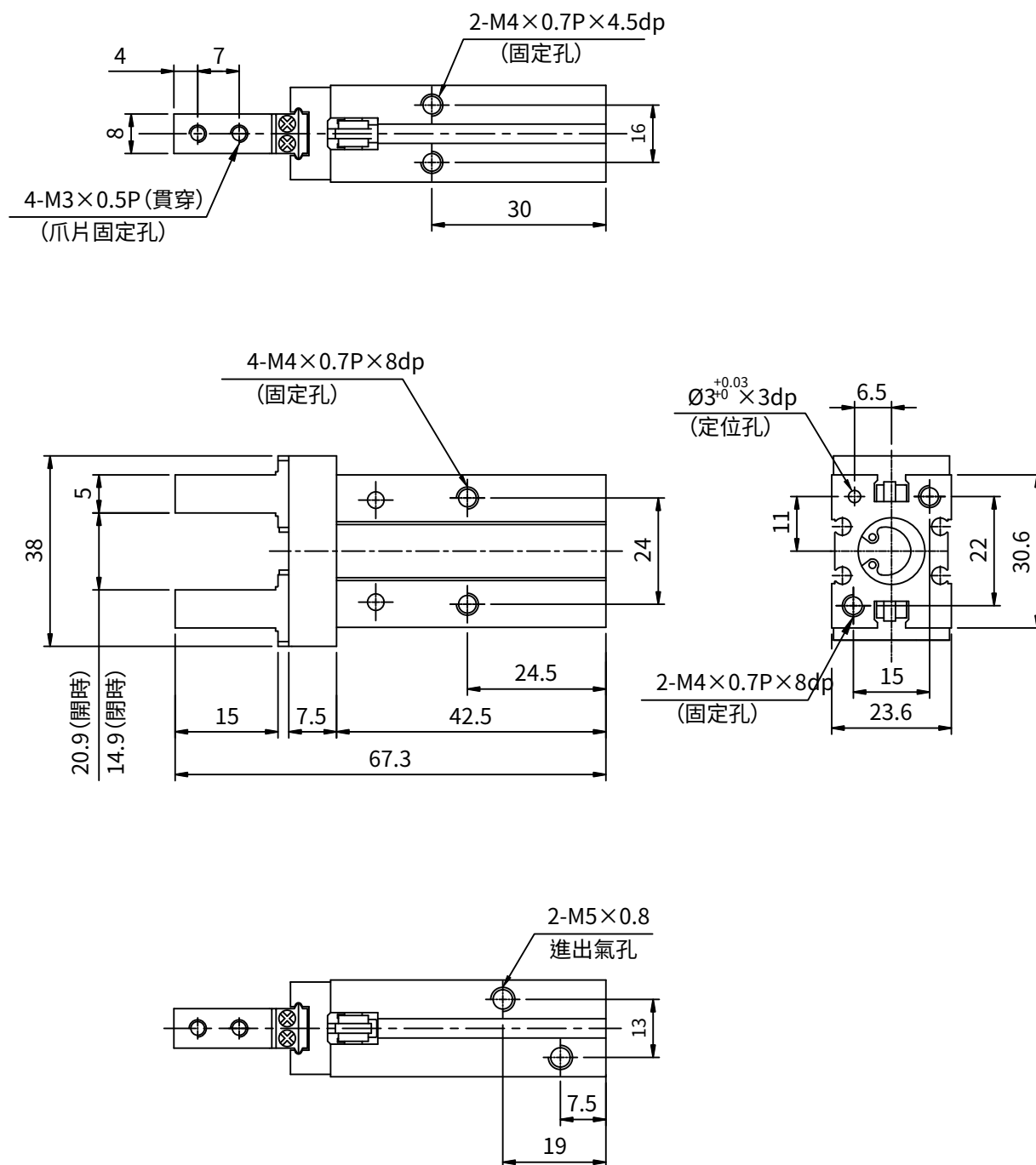

*單作用の場合、一側通孔變成呼吸孔

HDZ3S系列 滑軌型平行機械夾

外觀圖形尺寸



CHELIC PNEUMATIC

HDZ3S 20 (標準型)

復動型/單動型

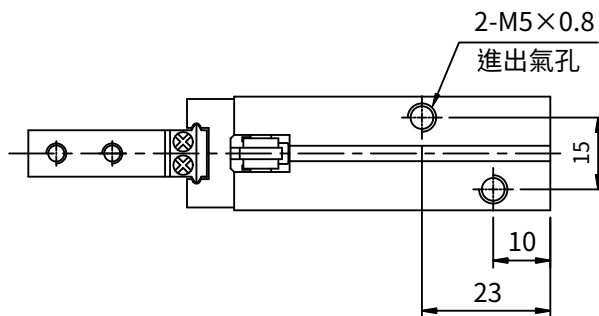
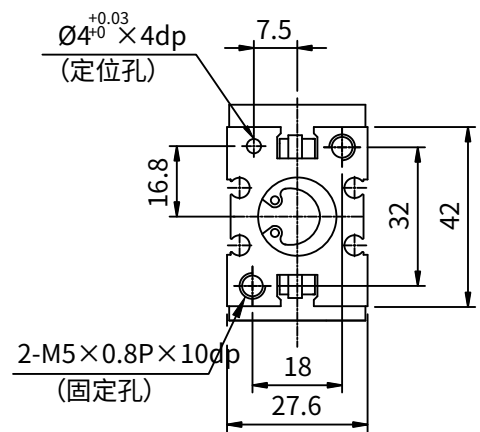
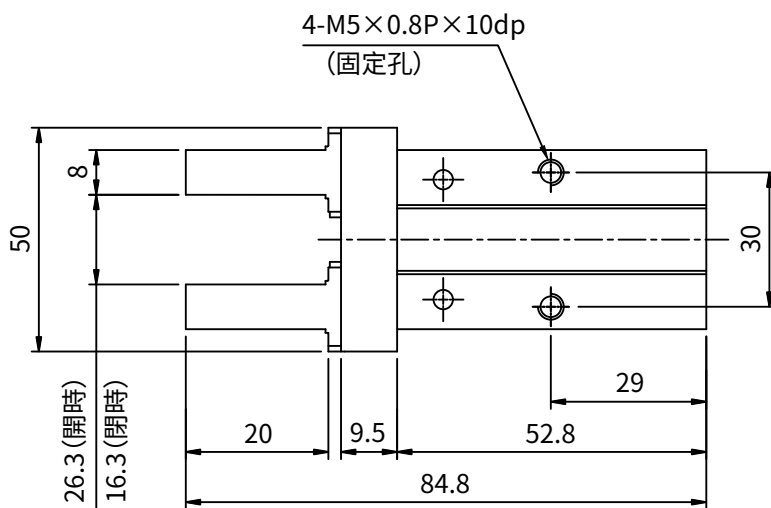
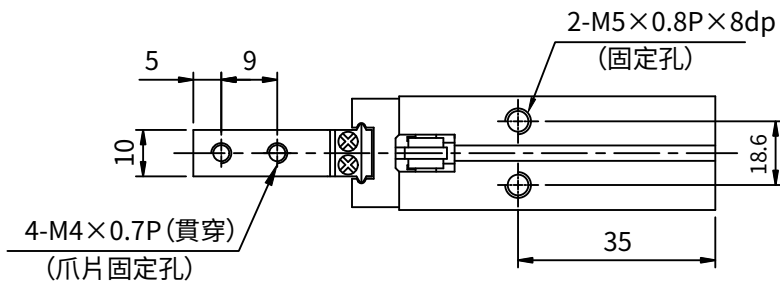

*單作用の場合、一側通孔變成呼吸孔

HDZ3S系列 滑軌型平行機械夾

外觀圖形尺寸



CHELIC PNEUMATIC

HDZ3S 25 (標準型)

復動型/單動型

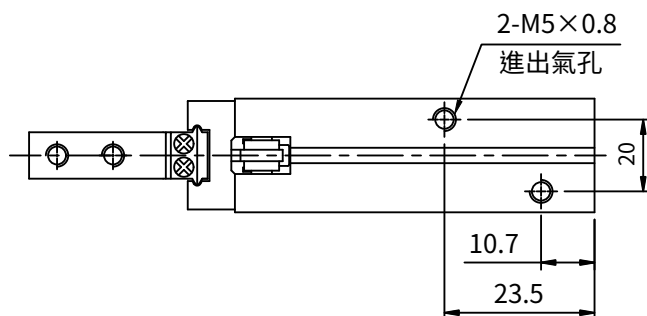
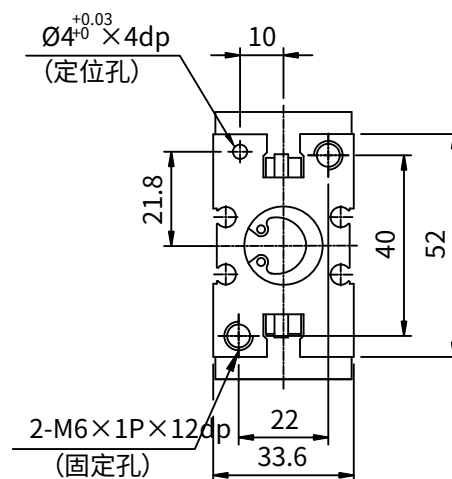
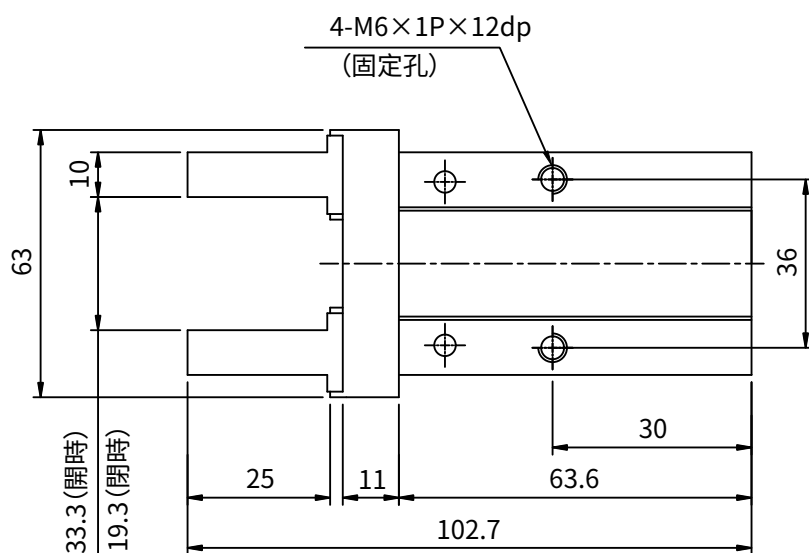
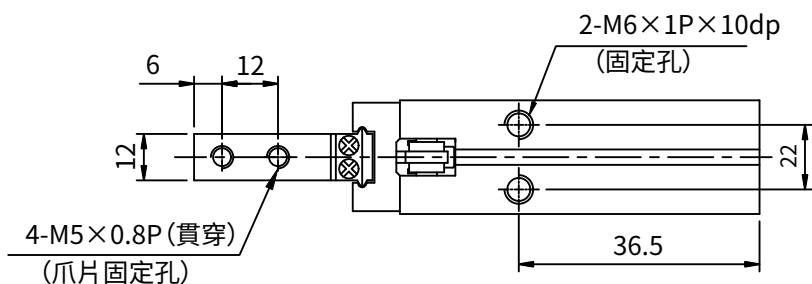

*單作用の場合、一側通孔變成呼吸孔

HDZ3S系列 滑軌型平行機械夾

外觀圖形尺寸



CHELIC PNEUMATIC

HDZ3 32 (標準型)

復動型/單動型

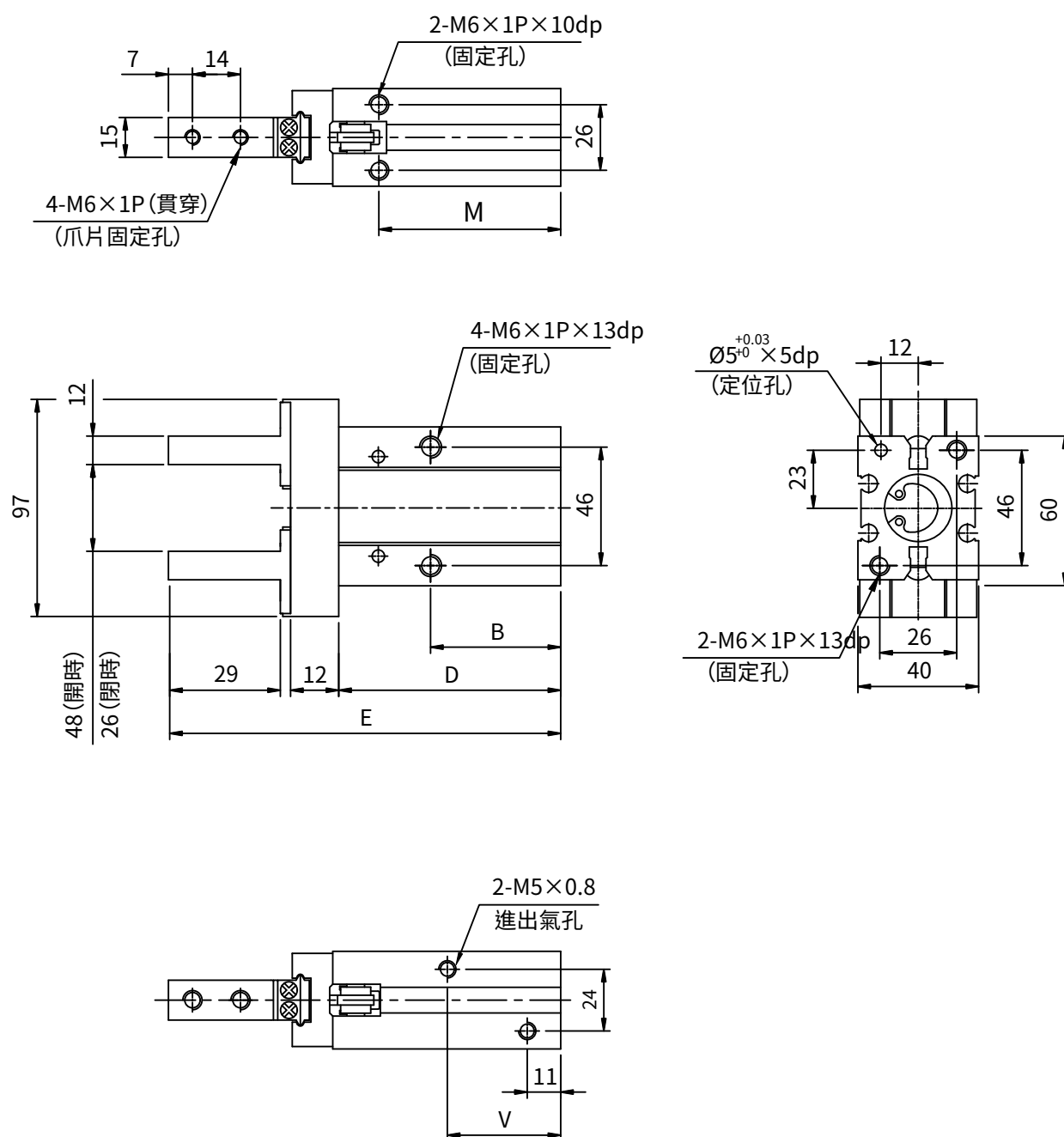

*單作用の場合，一側通孔變成呼吸孔

單位:mm

尺寸 規格	代號	B	D	E	M	V
	HDF3S 32 (復動)	40	67	113	48	31
	HDF3S 32 (單動)	49	76	122	57	37

HDZ3S系列 滑軌型平行機械夾

外觀圖形尺寸



CHELIC PNEUMATIC

HDZ3S 40 (標準型)

復動型/單動型

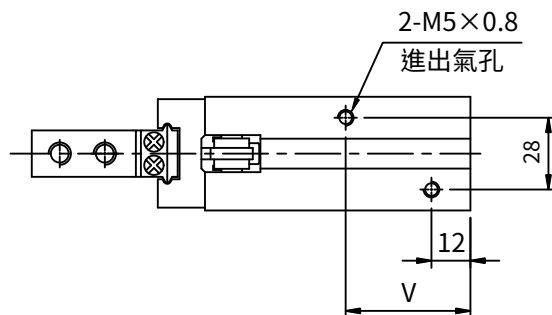
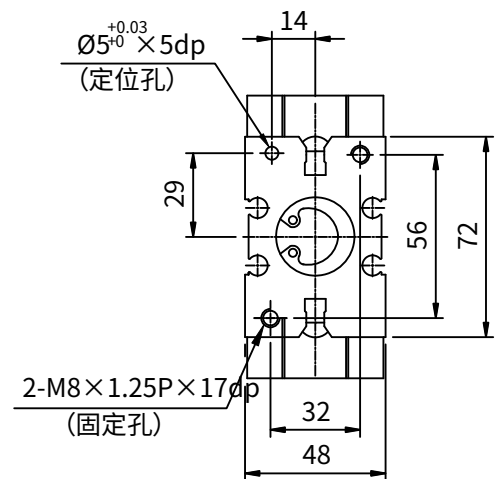
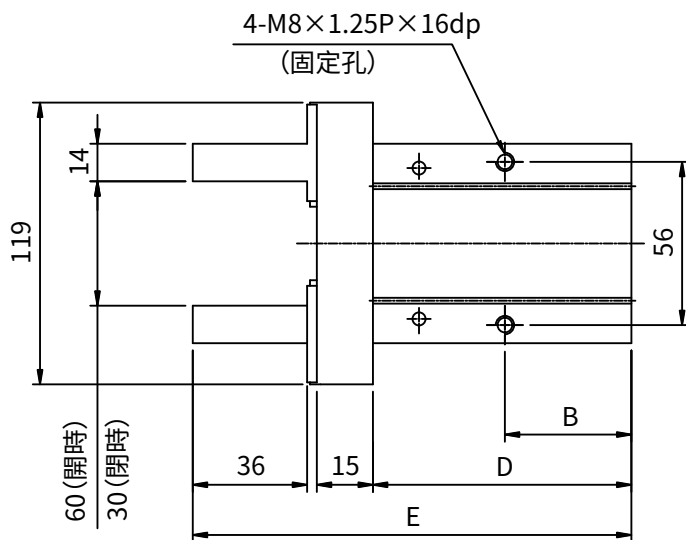
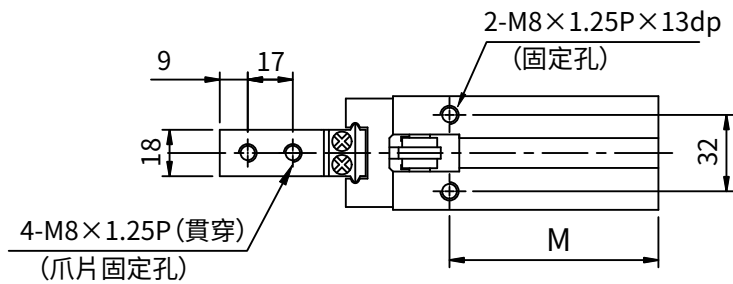

*單作用の場合，一側通孔變成呼吸孔

單位:mm

尺寸 規格	代號	B	D	E	M	V
	HDF3S 40 (復動)	49	83	139	58	38
	HDF3S 40 (單動)	62	96	152	71	45

HDZ3S系列 滑軌型平行機械夾

感應器固定型式



CHELIC PNEUMATIC

■ 感應器固定型式

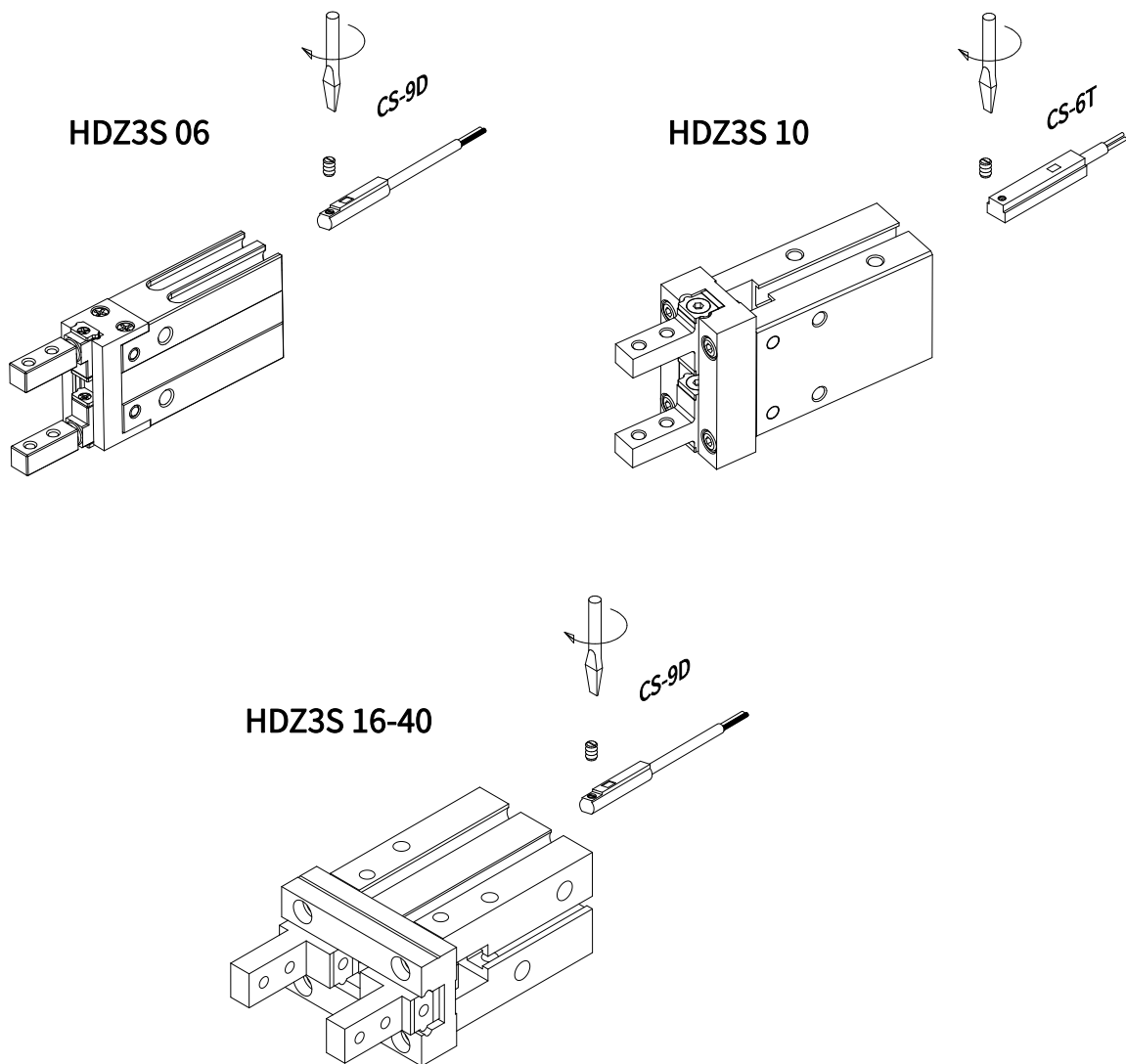

■ 感應範圍

感應器固定於本體上,當活塞移動而接近感應器時,磁鐵磁場促使磁簧開關動作之範圍;而磁場與開關之應答間約有 0.5mm 左右之誤差.

■ 感應器之設定與動作範圍

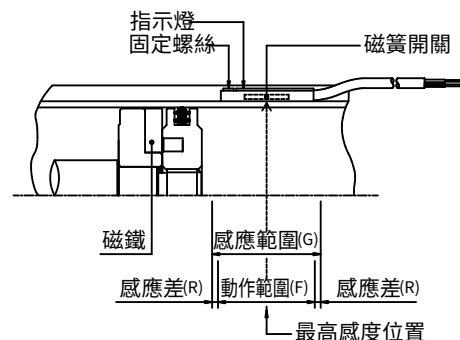

■ 接線型式

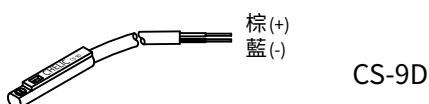

■ 接線型式

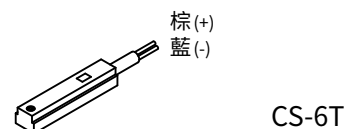

使用電壓: DC 5~120V

使用電壓: DC 5~120V