

接頭組件

作動規格表與訂購稱呼說明

CHELIC PNEUMATIC

內部結構圖

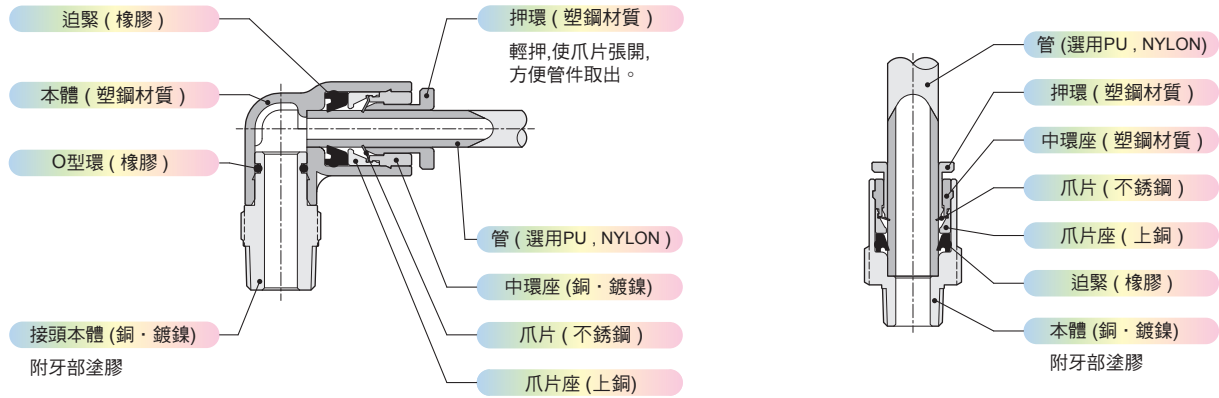

規格表

管徑		Ø4, Ø6, Ø8, Ø10, Ø12, Ø14, Ø16
使用流體	kgf/cm ² (kPa)	空氣
使用壓力範圍	kgf/cm ² (kPa)	9 (900)
保證耐壓力		10 (1000)
保證真空壓力		-100 Kpa (10 Torr)
使用溫度範圍	°C	5 ~ 60
材料	主體	黃銅 (鍍鎳)
	塑膠	NYLON, PBT, PP
連接口徑	Rc (PT/NPT)	M3, M5, M6, 1/8", 1/4", 3/8", 1/2"
牙部塗膠		附塗膠

訂購稱呼代號

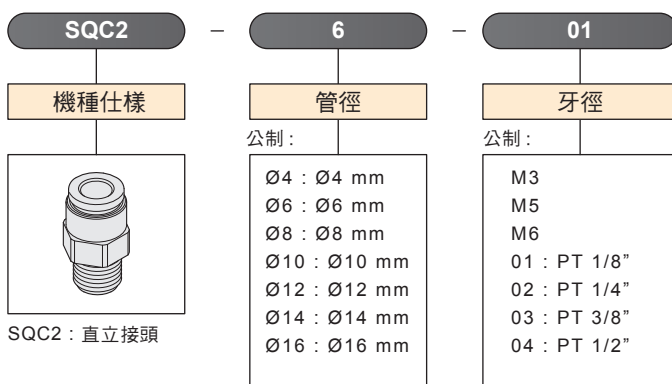

接頭組件

SQC2 系列

CHELIC PNEUMATIC

► SQC2 系列 直立接頭 (外牙)

公制規格

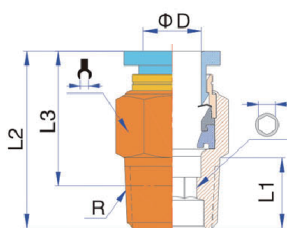

管徑 ØD	牙徑 Rc (PT)	型式	L1	L2	L3	對邊 H
Ø4	M5	SQC2 4-M5	3.5	20	16.5	10
	M6	SQC2 4-M6	4	20.5	16.5	10
	R1/8	SQC2 4-01	7.5	19.5	15.5	10
	R1/4	SQC2 4-02	10	19.5	13.5	14
	R3/8	SQC2 4-03	10.5	20.5	14	17
Ø6	M5	SQC2 6-M5	3.5	21	17.5	12
	M6	SQC2 6-M6	4	21.5	17.5	12
	R1/8	SQC2 6-01	7.5	21	17	12
	R1/4	SQC2 6-02	10	23	17	14
	R3/8	SQC2 6-03	10.5	21	14.5	17
	R1/2	SQC2 6-04	13.5	25	16.5	21
Ø8	R1/8	SQC2 8-01	7.5	26.5	22.5	14
	R1/4	SQC2 8-02	10	25	19	14
	R3/8	SQC2 8-03	10.5	21.5	15	17
	R1/2	SQC2 8-04	13.5	25.5	17.5	21
Ø10	R1/8	SQC2 10-01	7.5	29	25	17
	R1/4	SQC2 10-02	10	31	25	17
	R3/8	SQC2 10-03	10.5	27	20.5	17
	R1/2	SQC2 10-04	13.5	26	18	21
	R3/4	SQC2 10-06	15	28	18.5	27
Ø12	R1/8	SQC2 12-01	7.5	31.5	27.5	21
	R1/4	SQC2 12-02	10	34	28	21
	R3/8	SQC2 12-03	10.5	29.5	23	21
	R1/2	SQC2 12-04	13.5	32.5	24.5	21
	R3/4	SQC2 12-06	15	29	19.5	27
Ø14	R1/4	SQC2 14-02	10	34.5	28.5	22
	R3/8	SQC2 14-03	10.5	35	28.5	22
	R1/2	SQC2 14-04	13.5	33	24.5	22
	R3/4	SQC2 14-06	15	29.5	20	27
Ø16	R1/4	SQC2 16-02	10	36	30	24
	R3/8	SQC2 16-03	10.5	37	30.5	24
	R1/2	SQC2 16-04	13.5	37	28.5	24
	R3/4	SQC2 16-06	15	29.5	20	27

SQ □
接頭系列

QS □
調速接頭

QH □
手動開關

SL □
消音器

CJ-M
浮動接頭

PCR
空壓誘導
止回閥

SA □
油壓緩衝器

PU2
PU管

接頭組件

SQL2 系列

CHELIC PNEUMATIC

SQL2 系列 L型接頭

公制規格

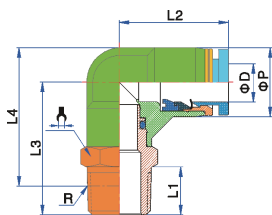

管徑 ØD	牙徑 Rc (PT)	型式	L1	L2	L3	L4	ØP	對邊 H
Ø4	M5	SQL2 4-M5	3.5	18.5	18.5	20.5	11	12
	M6	SQL2 4-M6	4		19	20.5		12
	R1/8	SQL2 4-01	7.5		21	22.5		12
	R1/4	SQL2 4-02	10		24	23.5		14
	R3/8	SQL2 4-03	10.5		25	24		17
Ø6	M5	SQL2 6-M5	3.5	19.5	19.5	22.5	13	12
	M6	SQL2 6-M6	4		20	22.5		12
	R1/8	SQL2 6-01	7.5		22	24.5		12
	R1/4	SQL2 6-02	10		25	25.5		14
	R3/8	SQL2 6-03	10.5		26	26		17
	R1/2	SQL2 6-04	13.5		29.5	27.5		21
Ø8	R1/8	SQL2 8-01	7.5	23	25	28.5	14.5	14
	R1/4	SQL2 8-02	10		27.5	29		14
	R3/8	SQL2 8-03	10.5		28.5	29		17
	R1/2	SQL2 8-04	13.5		32	31		21
Ø10	R1/8	SQL2 10-01	7.5	27	27.5	32.5	18.5	17
	R1/4	SQL2 10-02	10		30	33		17
	R3/8	SQL2 10-03	10.5		30.5	33		17
	R1/2	SQL2 10-04	13.5		34	35		21
	R3/4	SQL2 10-06	15		36.5	36		27
Ø12	R1/8	SQL2 12-01	7.5	29.5	28	34.5	21	17
	R1/4	SQL2 12-02	9.5		30.5	35		17
	R3/8	SQL2 12-03	10.5		31	35		17
	R1/2	SQL2 12-04	13.5		34.5	36.5		21
	R3/4	SQL2 12-06	15		37	38		27
Ø14	R1/4	SQL2 14-02	10	30	35.5	41	23	19
	R3/8	SQL2 14-03	11		37.5	43		19
	R1/2	SQL2 14-04	14		40	43		21
	R3/4	SQL2 14-06	15		42	44		27
Ø16	R1/4	SQL2 16-02	10	31.5	36.5	43.5	26	21
	R3/8	SQL2 16-03	11		39	45		21
	R1/2	SQL2 16-04	14		41.5	46		21
	R3/4	SQL2 16-06	15		43.5	47		27

接頭組件

SQH2, SQY2 系列

CHELIC PNEUMATIC

► SQH2 系列 二通接管

公制規格

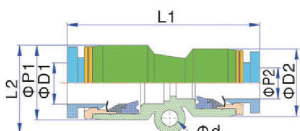

管徑		型式	L1	L2	ØP1	ØP2	Ød
ØD1	ØD2						
Ø4	Ø4	SQH2 4	32.5	13.5	11		3.2
Ø6	Ø6	SQH2 6	35	16	13		3.2
Ø8	Ø8	SQH2 8	38	17	14.5		3.2
Ø10	Ø10	SQH2 10	48	21.5	18.5		4.2
Ø12	Ø12	SQH2 12	48	24	21		4.2
Ø14	Ø14	SQH2 14	51.5	25.5	23		4.2
Ø16	Ø16	SQH2 16	64	28	26		5.2
Ø6	Ø4	SQH2 6-4	34	15	13	11	3.2
Ø8	Ø4	SQH2 8-4	36	16.5	14.5	13	3.2
Ø8	Ø6	SQH2 8-6	36.5	16.5	14.5	13	3.2
Ø10	Ø6	SQH2 10-6	43	19.5	18.5	13	3.2
Ø10	Ø8	SQH2 10-8	43	19.5	18.5	14.5	3.2
Ø12	Ø6	SQH2 12-6	47	23.5	21	18.5	4.2
Ø12	Ø8	SQH2 12-8	47	23.5	21	18.5	4.2
Ø12	Ø10	SQH2 12-10	48	23.5	21	18.5	4.2
Ø14	Ø12	SQH2 14-12	51	25	23	23	4.2
Ø16	Ø12	SQH2 16-12	64	28	26	26	5.2
Ø16	Ø14	SQH2 16-14	64.5	28	26	26	5.2

SQ□
接頭系列

QS□
調速接頭

QH□
手動開關

SL□
消音器

CJ-M
浮動接頭

PCR
空壓誘導
止回閥

SA□
油壓緩衝器

PU2
PU管

► SQY2 系列 T型三通接管

公制規格

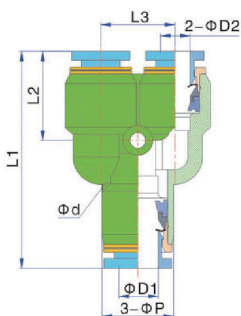

管徑		型式	L1	L2	L3	ØP	Ød
ØD1	ØD2						
Ø4	Ø4	SQY2 4	35.5	14	11	11	3.2
Ø6	Ø6	SQY2 6	38	15	13	13	3.2
Ø8	Ø8	SQY2 8	44.5	18.5	14.5	14.5	3.2
Ø10	Ø10	SQY2 10	50	21	18	18.5	4.2
Ø12	Ø12	SQY2 12	55	22	21	21	4.2
Ø14	Ø14	SQY2 14	55.5	22	26	26	4.2
Ø16	Ø16	SQY2 16	55.5	22	26	26	4.2
Ø6	Ø4	SQY2 6-4	37	14.5	13	13	3.2
Ø8	Ø4	SQY2 8-4	43.5	17.5	14.5	14.5	3.2
Ø8	Ø6	SQY2 8-6	43.5	17.5	14.5	14.5	3.2
Ø10	Ø6	SQY2 10-6	48.5	18.5	18	18.5	4.2
Ø10	Ø8	SQY2 10-8	49.5	20.5	18	18.5	4.2
Ø12	Ø8	SQY2 12-8	54	21	21	21	4.2
Ø12	Ø10	SQY2 12-10	54.5	21.5	21	21	4.2
Ø14	Ø12	SQY2 14-12	55	21.5	26	26	4.2
Ø16	Ø12	SQY2 16-12	55	21.5	26	26	4.2
Ø16	Ø14	SQY2 16-14	55.5	22	26	26	4.2

接頭組件

SQE2 , SQX2 系列

CHELIC PNEUMATIC

☉ SQE2 系列 T型三通接管

公制規格

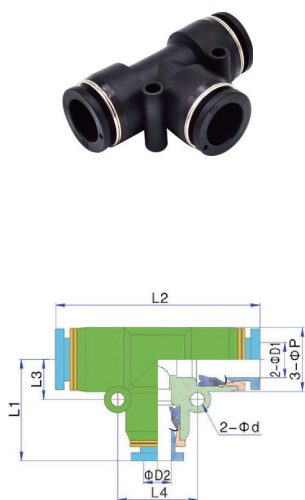

管徑		型式	ØP	L1	L2	L3	L4	Ød
ØD1	ØD2							
Ø4	Ø4	SQE2 4	11	18.5	37	7	14	3.2
Ø6	Ø6	SQE2 6	13	19	38	8	16	3.2
Ø8	Ø8	SQE2 8	14.5	23	46	9	18	3.2
Ø10	Ø10	SQE2 10	18.5	27.5	55	11.5	23	4.2
Ø12	Ø12	SQE2 12	21	29	58	13	26	4.2
Ø14	Ø14	SQE2 14	23	30	60	13.5	27	4.2
Ø16	Ø16	SQE2 16	26	32.5	65	14	28	4.2
Ø4	Ø6	SQE2 4-6	13	19	38	8	16	3.2
Ø6	Ø4	SQE2 6-4	13	19	38	8	16	3.2
Ø6	Ø8	SQE2 6-8	14.5	23	44	9	18	3.2
Ø8	Ø4	SQE2 8-4	14.5	22	46	9	18	3.2
Ø8	Ø6	SQE2 8-6	14.5	22	46	9	18	3.2
Ø8	Ø10	SQE2 8-10	18.5	27.5	54	11.5	23	4.2
Ø10	Ø6	SQE2 10-6	18.5	26	55	11.5	23	4.2
Ø10	Ø8	SQE2 10-8	18.5	27	55	11.5	23	4.2
Ø10	Ø12	SQE2 10-12	21	29	59	13	26	4.2
Ø12	Ø8	SQE2 12-8	21	29	58	13	26	4.2
Ø12	Ø10	SQE2 12-10	21	29.5	58	13	26	4.2
Ø14	Ø12	SQE2 14-12	23	29	60	13.5	27	4.2
Ø16	Ø12	SQE2 16-12	26	32	65	14	28	5.2
Ø16	Ø14	SQE2 16-14	26	32.5	65	14	28	5.2

☉ SQX2 系列 四通接管

公制規格

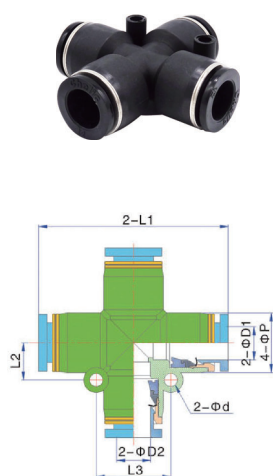

管徑		型式	ØP	L1	L2	L3	Ød
ØD1	ØD2						
Ø4	Ø4	SQX2 4	11	37	7.5	15	3.2
Ø6	Ø4	SQX2 6-4	13	38	8	16	3.2
Ø6	Ø6	SQX2 6	13	38	8	16	3.2
Ø8	Ø6	SQX2 8-6	14.5	45	9	18	3.2
Ø8	Ø8	SQX2 8	14.5	45	9	18	3.2
Ø10	Ø8	SQX2 10-8	18.5	56	11.5	23	4.2
Ø10	Ø10	SQX2 10	18.5	56	11.5	23	4.2
Ø12	Ø10	SQX2 12-10	21	58	13	26	4.2
Ø12	Ø12	SQX2 12	21	58	13	26	4.2

接頭組件

SQF2 , SQW2 , SQMH2 系列

CHELIC PNEUMATIC

► SQF2 系列 五通接管

公制規格

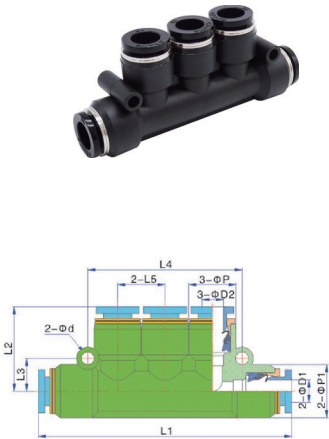

管徑		型式	L1	L2	L3	L4	L5	ØP1	ØP2	Ød
ØD1	ØD2									
Ø4	Ø4	SQF2 4	59	19	8	37.5	11	13	11	3.2
Ø6	Ø5	SQF2 6	69	23	8.5	42	13	14.5	13	3.2
Ø8	Ø6	SQF2 8	78.5	25	11	47.5	14.5	18.5	14.5	4.2
Ø10	Ø7	SQF2 10	91.5	29.5	12.5	60	18.5	21	18.5	4.2
Ø12	Ø8	SQF2 12	100	29.5	13	68.5	21	21	21	4.2
Ø6	Ø9	SQF2 6-4	60	19	8	37.5	11	13	11	3.2
Ø8	Ø10	SQF2 8-4	71	22	8.5	42	13	14.5	13	3.2
Ø8	Ø11	SQF2 8-6	71	23	8.5	42	13	14.5	13	3.2
Ø10	Ø12	SQF2 10-6	79.5	24	11	47.5	14.5	18.5	14.5	4.2
Ø10	Ø13	SQF2 10-8	79.5	25	11	47.5	14.5	18.5	14.5	4.2
Ø12	Ø14	SQF2 12-6	93.5	28	12.5	60	18.5	21	18.5	4.2
Ø12	Ø15	SQF2 12-8	93.5	29	12.5	60	18.5	21	18.5	4.2
Ø12	Ø16	SQF2 12-10	93.5	29.5	12.5	60	18.5	21	18.5	4.2

► SQW2 系列 Y型五通接頭

公制規格

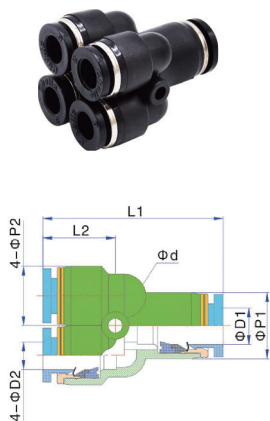

管徑		型式	L1	L2	L3	ØP1	ØP2	Ød
ØD1	ØD2							
Φ8	Φ4	SQW2 8-4	38.5	15.5	13	14.5	13	3.2
Φ8	Φ6	SQW2 8-6	38.5	15.5	13	14.5	13	3.2
Φ6	Φ6	SQW2 6-6	38.5	15.5	13	14.5	13	3.2

► SQMH2 系列 螺牙接管

公制規格

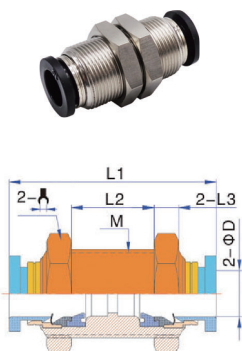

管徑 ØD	牙徑 Rc (PT)	型式	L1	L2	L3	對邊 H
Φ4	M12x1	SQMH2 4-4	31	13	3.5	14
Φ6	M14x1	SQMH2 6-6	33	13	4	17
Φ8	M16x1	SQMH2 8-8	37.5	15	4.5	19
Φ10	M20x1	SQMH2 10-10	42.5	18.5	5	21
Φ12	M22x1	SQMH2 12-12	46.5	20	5	27
Φ14	M24x1	SQMH2 14-14	48	20	5.5	30
Φ16	M26x1	SQMH2 16-16	50.5	22	6	32

SQ□
接頭系列

QS□
調速接頭

QH□
手動開關

SL□
消音器

CJ-M
浮動接頭

PCR
空壓誘導
止回閥

SA□
油壓緩衝器

PU2
PU管

接頭組件

SQZ2 , SQHJ2 系列

CHELIC PNEUMATIC

◀ SQZ2 系列 L型迴轉接頭

公制規格

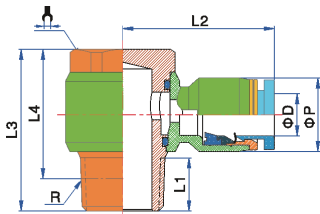

管徑 ØD	牙徑 Rc (PT)	型式	L1	L2	L3	L4	ØP	對邊 H
Ø4	M5	SQZ2 4-M5	4	20	17	13	11	8
	M6	SQZ2 4-M6	4	20	18	14	11	8
	R1/8	SQZ2 4-01	7	23	24	20	11	12
	R1/4	SQZ2 4-02	9.5	25	26.5	20.5	11	14
Ø6	M5	SQZ2 6-M5	4	21.5	17	13	13	8
	M6	SQZ2 6-M6	4	21.5	18	14	13	8
	R1/8	SQZ2 6-01	7	23	24	20	13	12
	R1/4	SQZ2 6-02	9.5	25	26.5	20.5	13	14
	R3/8	SQZ2 6-03	10.5	27	32	25.5	13	19
Ø8	R1/2	SQZ2 6-04	14	33	39	31	14.5	24
	R1/8	SQZ2 8-01	7	26.5	24	20	14.5	12
	R1/4	SQZ2 8-02	9.5	29	26.5	20.5	14.5	14
	R3/8	SQZ2 8-03	10.5	30.5	32	25.5	14.5	19
Ø10	R1/2	SQZ2 8-04	14	33	39	31	14.5	24
	R1/8	SQZ2 10-01	7	29	24	20	18.5	12
	R1/4	SQZ2 10-02	9.5	31	26.5	20.5	18.5	14
	R3/8	SQZ2 10-03	10.5	32	32	25.5	18.5	19
Ø12	R1/2	SQZ2 10-04	14	34.5	39	31	18.5	24
	R1/4	SQZ2 12-02	9.5	33	26.5	20.5	21	14
	R3/8	SQZ2 12-03	10.5	35	32	25.5	21	19
Ø14	R1/2	SQZ2 12-04	14	36.5	39	31	21	24
	R3/8	SQZ2 14-04	14	39	39	31	26	24
Ø16	R1/2	SQZ2 16-04	14	39	39	31	26	24

◀ SQHJ2 系列 插管式接頭

公制規格

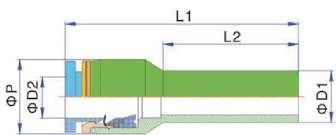

管徑		型式	L1	L2	ØP
ØD1	ØD2				
Φ6	Φ4	SQHJ2 6-4	38.5	22	11
Φ8	Φ4	SQHJ2 8-4	40	25	11
Φ8	Φ6	SQHJ2 8-6	41	25	13
Φ10	Φ6	SQHJ2 10-6	41	26.5	13
Φ10	Φ8	SQHJ2 10-8	45.5	26.5	14.5
Φ12	Φ6	SQHJ2 12-6	40	26.5	13
Φ12	Φ8	SQHJ2 12-8	43	26.5	14.5
Φ12	Φ10	SQHJ2 12-10	51	26.5	18.5

接頭組件

SQLJ2 系列

CHELIC PNEUMATIC

SQLJ2 系列 L型二通接頭

公制規格

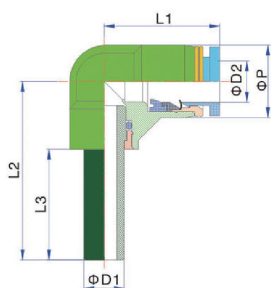

管徑		型式	L1	L2	L3	ØP
ØD1	ØD2					
Ø4	Ø4	SQLJ2 4	18.5	28.5	18.5	11
Ø6	Ø4	SQLJ2 6-4	18.5	29	19	11
Ø6	Ø6	SQLJ2 6	19.5	30	19	13
Ø8	Ø6	SQLJ2 8-6	22	35.5	22	14.5
Ø8	Ø8	SQLJ2 8	23	35.5	22	14.5
Ø10	Ø8	SQLJ2 10-8	26.5	39	23.5	18.5
Ø10	Ø10	SQLJ2 10	27	39	23.5	18.5
Ø12	Ø10	SQLJ2 12-10	27	42	26.5	18.5
Ø12	Ø12	SQLJ2 12	29.5	42.5	26.5	21

SQ □
接頭系列

QS □
調速接頭

QH □
手動開關

SL □
消音器

CJ-M
浮動接頭

PCR
空壓誘導
止回閥

SA □
油壓緩衝器

PU2
PU管